

Technical data sheet



Product features

Panini grill grooved electric grooved upper plate 26x24 230 V

Model	SAP Code	00003499
--------------	-----------------	----------



- Top type: Grooved
- Griddle dimensions [mm x mm]: 260 x 240
- Griddle thickness [mm]: 8.00
- Container for liquid fat: Yes
- Independent heating zones: Joint control of top and bottom plate
- Maximum device temperature [°C]: 300
- Surface finish: sandblasted surface without coating

SAP Code	00003499	Power electric [kW]	3.000
Net Width [mm]	304	Loading	230 V / 1N - 50 Hz
Net Depth [mm]	407	Griddle dimensions [mm x mm]	260 x 240
Net Height [mm]	189	Top type	Grooved
Net Weight [kg]	15.00		

Technical data sheet

Technical drawing



Panini grill grooved electric grooved upper plate 26x24 230 V

Model

SAP Code

00003499

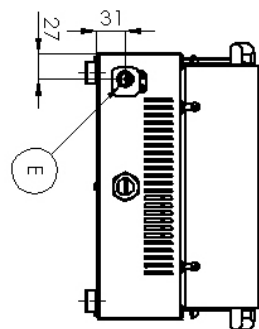
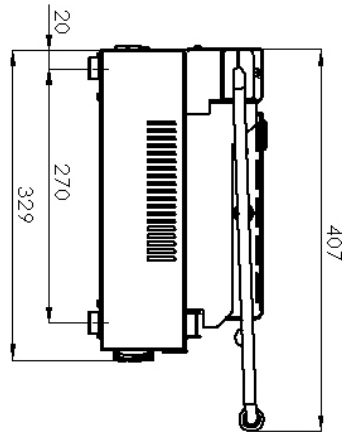
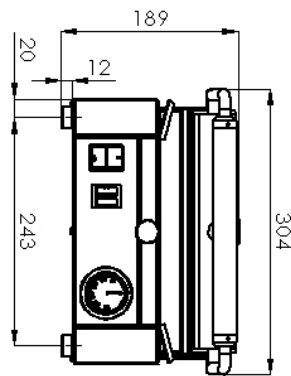

Technical data sheet



Product benefits

Panini grill grooved electric grooved upper plate 26x24 230 V

Model

SAP Code

00003499

1

All-stainless design

only stainless steel intended for food contact is used

- absolutely rust-proof and non-magnetic design
- resists even weak acids easier compliance with hygiene standards (HACCP); easy maintenance and cleaning

2

Run and warm-up light

optical possibility to check the status of the device

- the operator immediately knows what state the appliance is in on/off, heating/not heating

3

Outlet for waste liquids

waste fluid, the fat is no longer burned and drains into the reservoir (drawer)

- the waste liquid (grease) is not burned off and does not flow onto the table or the floor

4

Grill plate with steel alloy 8mm

high thermal conductivity strength stability

- quick heat up the grill plate does not warp or bulge
- faster heating than cast iron
- grills better than stainless steel
- food does not stick to it

Technical data sheet



Technical parameters

Panini grill grooved electric grooved upper plate 26x24 230 V

Model

SAP Code

00003499

1. SAP Code:

00003499

2. Net Width [mm]:

304

3. Net Depth [mm]:

407

4. Net Height [mm]:

189

5. Net Weight [kg]:

15.00

6. Gross Width [mm]:

470

7. Gross depth [mm]:

330

8. Gross Height [mm]:

230

9. Gross Weight [kg]:

16.00

10. Device type:

Electric unit

11. Construction type of device:

Table top

12. Power electric [kW]:

3.000

13. Loading:

230 V / 1N - 50 Hz

14. Protection of controls:

IPX4

15. Material:

Stainless steel

16. Indicators:

operation and warm-up

17. Surface finish:

sandblasted surface without coating

18. Maximum device temperature [°C]:

300

19. Minimum device temperature [°C]:

50

20. Griddle dimensions [mm x mm]:

260 x 240

21. Griddle thickness [mm]:

8.00

22. Container for liquid fat:

Yes

23. Independent heating zones:

Joint control of top and bottom plate

24. Uniform heating:

Yes

25. Top type:

Grooved

26. Power consumption of the zone 1 [kW]:

1,8

27. Power consumption of the zone 2 [kW]:

1,2